

Drum Chipper

Bio mass Reduction

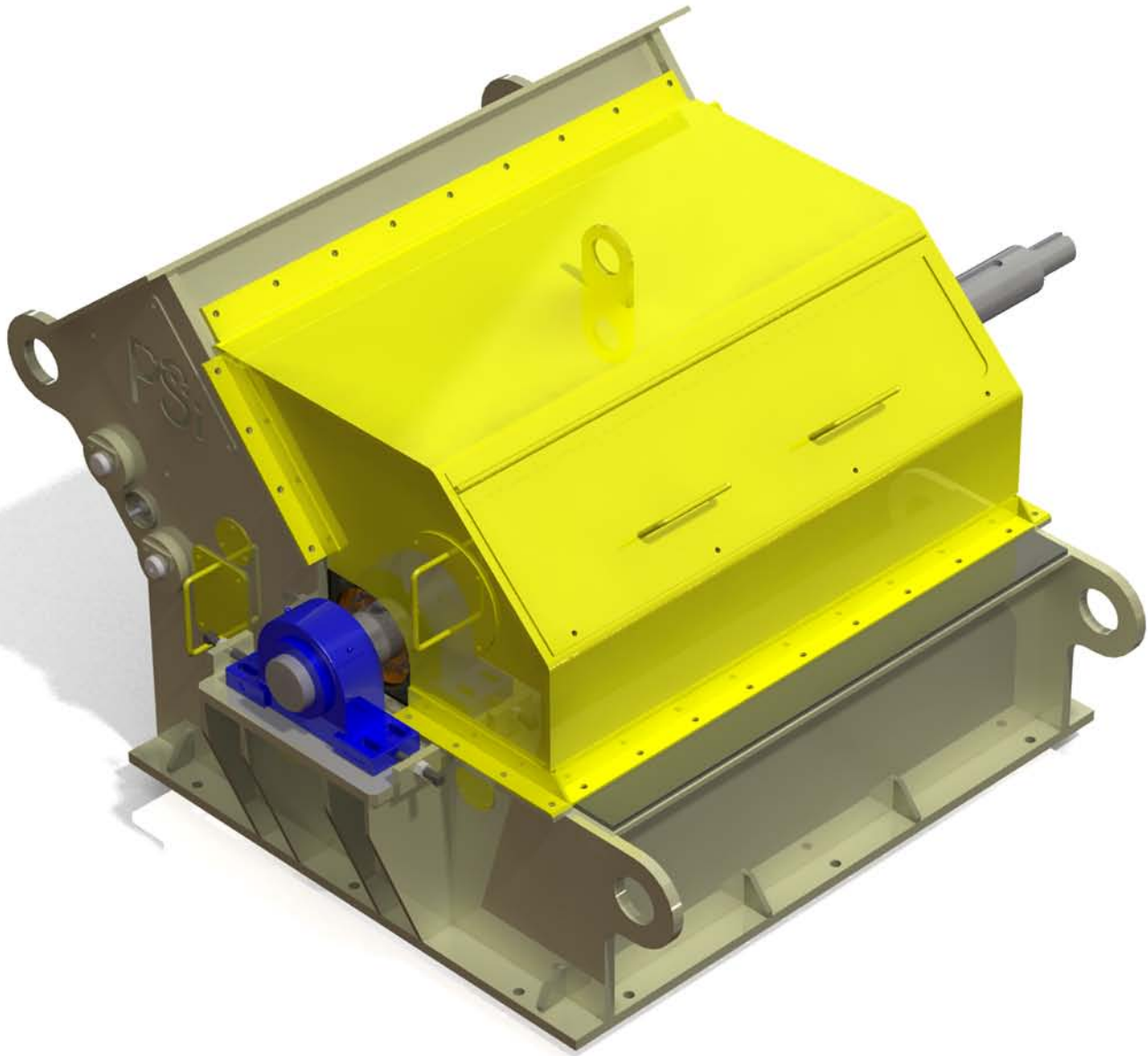

Material reduction to 1/8"
Low HP compared with hammer mill
Gravity feed
Adjustable screens
Adjustable particle size
Various width
Re- grindable knives

PSi
Pellet Systems International

Drop Feed Drum Chipper

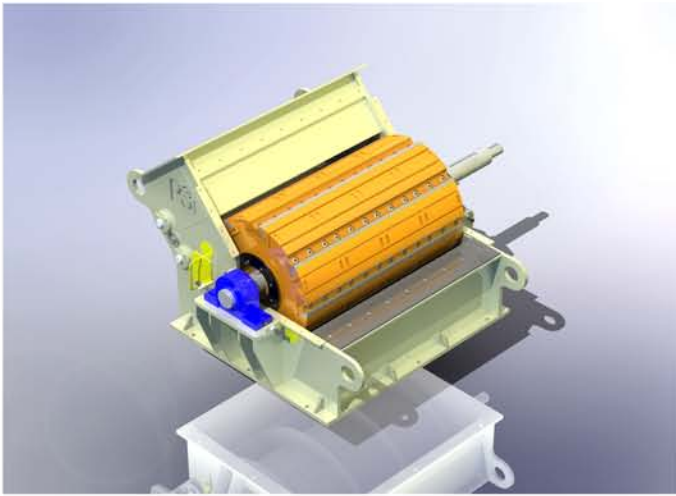

- Reduction of coarse bio mass Prior to drying
- Adjustable chip size from 1/8 to 3/4 in length
- Various screens to match particle size, material and application
- Softwood, hardwood and other biomass

- High speed chipper knife design
- Optional stellite or carbide knives
- Adjustable knife length
- High speed steel face knife
- 8 knife or 5 knife head
- Taper locks for head
- Head is made in 12" wide sections

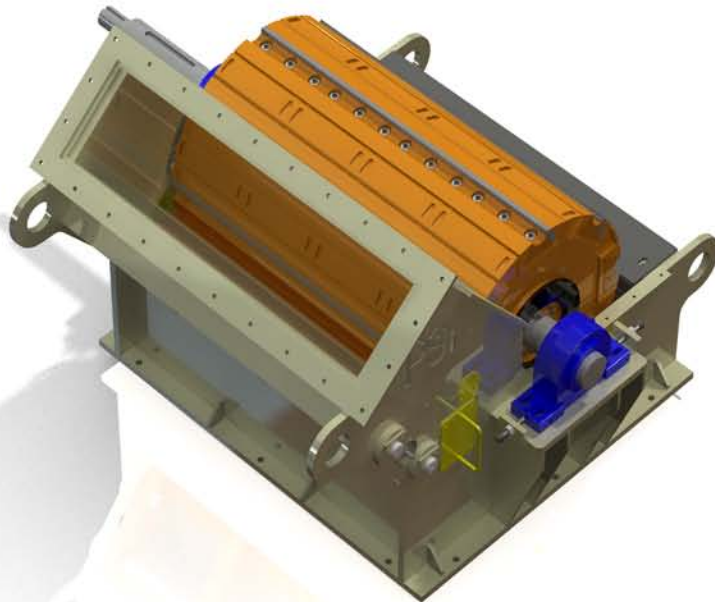
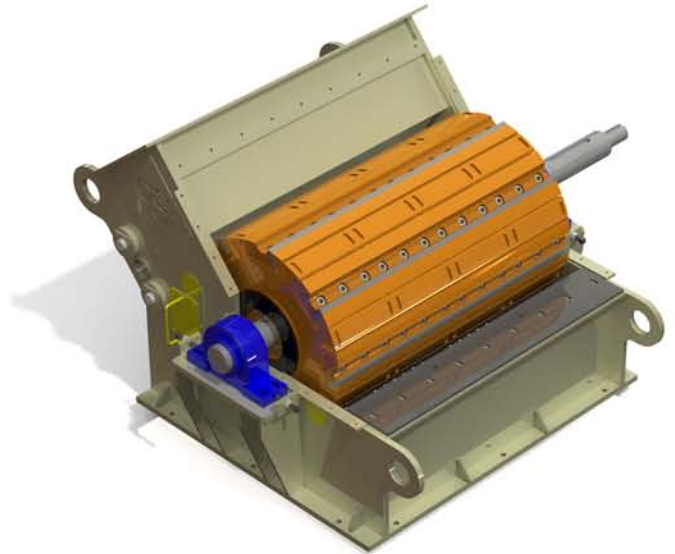

- Head width 12", 24", 36", 48" or 60" wide
- Head diameter 30" diameter
- 4 7/16 precision ground shaft
- Double spherical roller bearings
- Head lock on shaft with taperlocks and keyways
- 100 hp to 600 hp designed for your application

Pellet Systems International
26 Pinder Road
Nackawic, NB E6G 1W3
Tel: (506) 575-2231
Fax: (506) 575-2380
e - mail: info@pelletsystems.com
web: www.pelletsystems.com

Pellet Systems International